

# OPERATION MANUAL

*Relex* 28-7

SER. NO. HY2870001~

 **HYUNDAI**  
HEAVY INDUSTRIES CO.,LTD.

[\*http://marengine.com/r28-7-excavator\*](http://marengine.com/r28-7-excavator)

# INTRODUCTION

## **▲ WARNING**

Read this manual carefully before operating the machine to ensure safe and optimum running conditions. If you do not understand any of the points in the manual, or the machine breaks down, contact your dealer. In particular, attention needs to be paid to the following points.

- Read this operation manual if you have any questions or doubts on any point to ensure proper and safety excavator operation.
- Keep this operation manual in the excavator at any time to ensure readily access to it in case a need for it arises.
- Be sure to hand over this operation manual to the new owner if the ownership of the excavator is to be transferred.
- Make every possible effort to ensure proper and safety operation of the excavator.

- Note that a portion of the contents of this instruction manual may differ from the excavator you have purchased, which is mainly due to the improvements adopted for it.
- Consult our marketing staff if you have any questions or comments on this operation manual.

# HOW TO USE THE OPERATION MANUAL

Read this manual carefully before operating the machine.  
This chapter describes the marks in the operation manual.

## Symbols:

### **DANGER**

This symbol shows an immediate hazard that will cause death or severe injury if the instruction is not observed.

### **WARNING**

This symbol shows a hazard that can cause death or severe injury if the instruction is not observed.

### **CAUTION**

This symbol shows a hazard that can cause injury of machine damage if the instruction is not observed.

### **IMPORTANT**

This symbol shows a hazard that can cause damages to the excavator or reduce its service life if the instruction is not observed.

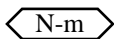

This symbol shows the tightening torque for a given bolt that needs to be strictly observed during the assembly.



This symbol shows related matters or the referring page.



This symbol shows the amount of grease or oil that needs to be filled.

- If you notice any ambiguous points in this manual, consult your dealer.
- The descriptions and figures in this operation manual may not coincide with the machine due to changes in the specifications.





# CONTENTS

## OPERATION

Safety Decals .....	1
Basic Precautions on Safety .....	3
Safety Precautionary Notes before Start .....	4
Safety Precautions during Operation .....	6
Safety Precautions during Inspection and Maintenance .....	15
Safety Post Operational Caution .....	18
Part Names .....	19
Explanation of Each Device .....	21
Operation .....	28
Operational Precautions .....	32
Transporting by Truck .....	39
Machine Traction .....	41
How to Hoist a Machine .....	42
Cold Weather or During-Winter Operations .....	44
Long-Period Storage .....	46

## INSPECTION AND MAINTENANCE

Ordering Parts and Servicing Guidelines .....	47
Inspections .....	48
Maintenance after the First 50 Service Hours (New Machine) .....	53
Maintenance after the First 100 Service Hours (New Machine) .....	54
Maintenance Every 50 Service Hours .....	55
Maintenance Every 100 Service Hours .....	57
Maintenance Every 250 Service Hours .....	58
Maintenance Every 500 Service Hours .....	59
Maintenance Every 1000 Service Hours .....	61
To Pressurize .....	62
Inspection and Maintenance Procedures .....	64
Periodical Inspections and Maintenance List .....	70
Lubricants .....	72

## OTHERS

Dimensions and Specifications .....	76
PTO Flow .....	78
Lifting Capacities .....	79
Hydraulic Circuit .....	82
Electric Circuit .....	83
Consumables List .....	84

# OPERATION

## MACHINE RUNNING-IN

### 1. Precautions to running in the new machine

The new machine was inspected and adjusted completely on delivery from the factory. However, be sure to inspect it as follows before use. For the first 50 service hours, warm up at 60 to 70% of full load.

Do not operate at an unreasonable load. Trouble may occur, thereby reducing the service life.

- Body  
Check if there are any damaged or loose parts caused during transit.
- Control system  
Check if there is an abnormality in the operation of the control lever and control unit.
- Cooling system  
Check if the radiator coolant is filled to the specified level and water leakage occurs or not. Check also expansion tank level
- Engine system  
Check that engine is filled with the proper amount of oil.  
Check for oil and fuel leakages.
- Electric system  
Check for loose wiring, battery fluid level and loose terminal connections.
- Greasing and lubricating  
Check if the parts are greased and lubricated sufficiently.  
Check the crawler tension.

### 2. Replacing engine oil and elements of the new machine

- Replace engine oil and elements of the new machine after 50 service hours.
- Replace the line filter of the new machine after 100 service hours.
- Clean the suction filter of the new machine after 100 service hours.
- Replace the gear oil for the travelling and reduction gears of the new machine after 500 service hours.

 **Refer to "Lubricants" on page 72.**

# OPERATION

## BEFORE STARTING ENGINE

- 1) Execute the inspection before starting operation.  
☞ **Refer to "Inspection" on page 48.**
- 2) Make sure of the travelling lever at neutral.
- 3) Push back the acceleration lever to revolve the engine at medium speed or more.
- 4) It is normal that the lamps light up at "ON" and should go out as the engine starts running.

### ▲ CAUTION

- Starting up with the accelerator lever at full stroke is very dangerous.
- Look around the machine to confirm that no unauthorized person is within the working area and blow the horn before starting the engine.

## STARTING PROCEDURE

1. Turn the key from OFF to GLOW, and the charger and lamp circuits are electrified.  
Leave it for 5 seconds to pre-heat the starter before turning the key to START.
2. Turn the key from ON to START. Engine starts running.
3. Immediately take your hand off the key when the engine starts.

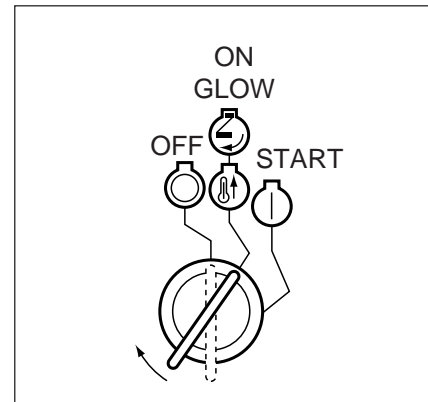

### ▲ CAUTION

Do not continue to operate the starter for more than 15 seconds. To do so will damage the starter. If engine does not start, return the key to the OFF position and try again after 30 seconds.

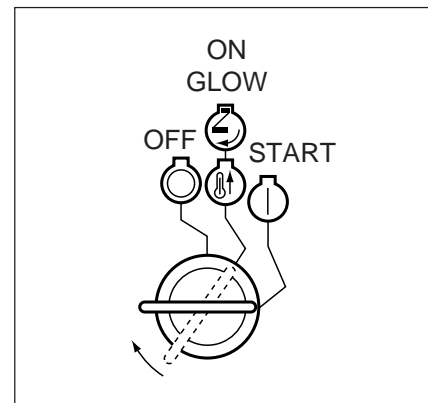

4. Return the accelerator lever to the idling position to warm up the machine.

### ▲ CAUTION

Never turn the key to START while the engine is running.

### IMPORTANT

If engine does not start after several attempts, check the fuel level and battery.



# OPERATION

## PRECAUTION AFTER STARTING ENGINE

1. Idle engine until the warning lights go out.
2. Do not accelerate rapidly until the machine is warmed up.

### IMPORTANT

Sufficiently warm up the engine before starting the work if the machine is to be operated in the wintertime or frigid region.

## STOPPING ENGINE

1. Slowly work left and right operation levers to lower the bucket on the ground.
2. Before stopping engine, idle it for about 5 minutes to cool it down.
3. Return the accelerator lever to engine stop position.
4. Return the starter switch to OFF and remove the key.

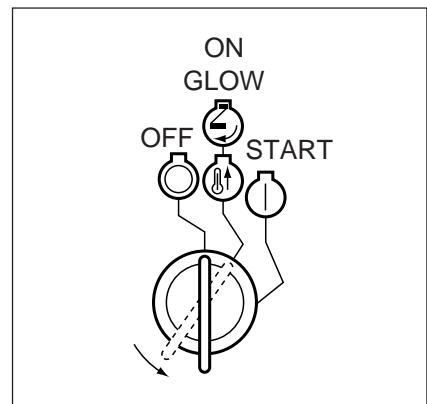

### IMPORTANT

Leaving the starter switch ON after stopping engine will drain the battery. Always turn off the starter switch after stopping engine.

# OPERATION

## TRAVELLING

1. Fold the boom and arm. Raise them to 40 to 50 cm (15"-20") above the ground.
2. Raise the dozer blade at minimum stroke.
3. Check the direction you want to go. Move the left and right crawler operation levers forward for forward travelling or backward for reverse travelling.

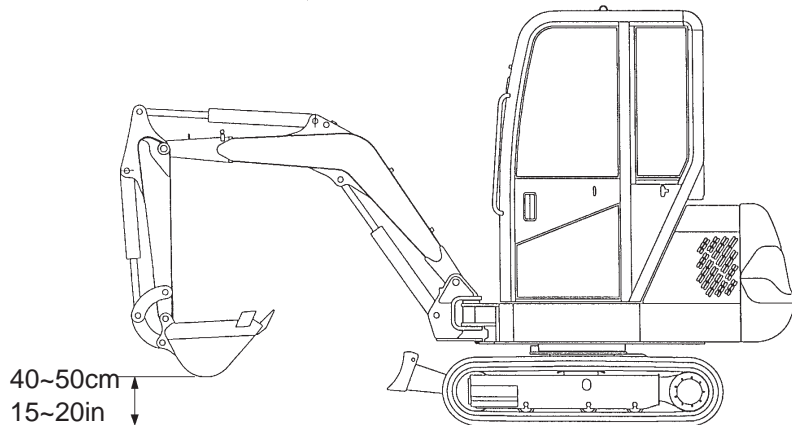

### Turning the Stationary Machine

Push the left travelling lever forward to turn the machine to the right. Pull the left travelling lever backward to turn the rear of the machine to the right.

### Turning the Machine while Travelling

#### 1. Left pivot-turn

Return the left crawler lever to neutral position with the right crawler lever pushed forward.

#### 2. Right pivot-turn

Return the right crawler lever to the neutral position with the left crawler lever pushed forward.

#### 3. Spin turning

Turning the left crawler lever forward and right crawler lever backward and the machine spins rightward. For the spin leftward, operate in the opposite way.

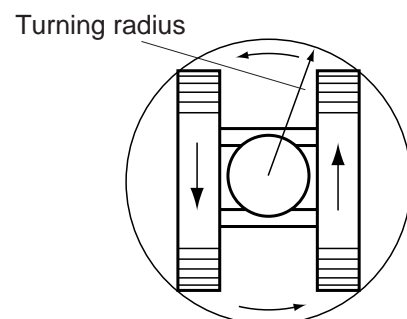
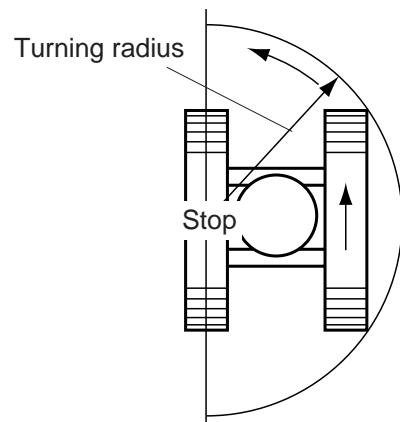

### ⚠ CAUTION

You cannot make a spin turn or a pivot turn at high speed.  
A spin turn on the concrete surface damaged rubber shoes.

# MAINTENANCE AFTER THE FIRST 50 SERVICE HOURS (NEW MACHINE)

## 1) Replacing engine oil filter cartridge

1. Warm up the engine (for about 10 minutes), as the engine oil should be warm before replacing the cartridge.
2. Remove the drain plug of the oil pan, and drain the oil.

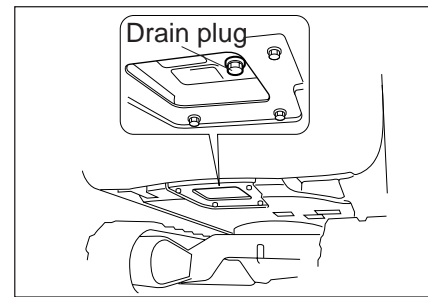

3. Remove the cartridge with a filter wrench.
4. Slightly coat the O-ring of the new cartridge with oil and firmly tighten the cartridge by hand.

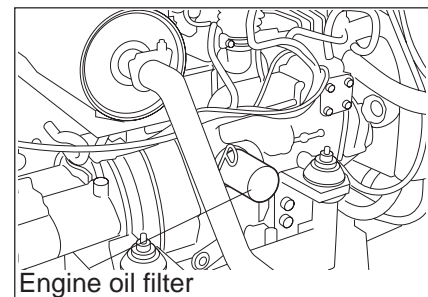

5. Securely replace the drain plug, and add the specified amount of engine oil through the oil supply port.
6. Start and idle the engine for several minutes to check for oil leakage. After the engine is stopped, check the oil level using the level gauge. If short, add oil.

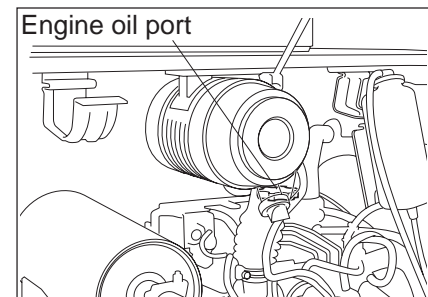

\* **Perform this operation on flat ground. Make sure that dust does not enter through the oil supply port.**

 4.5 ℓ

# MAINTENANCE AFTER THE FIRST 100 SERVICE HOURS (FOR NEW MACHINE)

- 1) Replacing the line filter element  
Remove the filter with a filter wrench and replace it with new one.

## IMPORTANT

Before replacing the filter, be sure to open the hydraulic oil tank to bleed the filter.

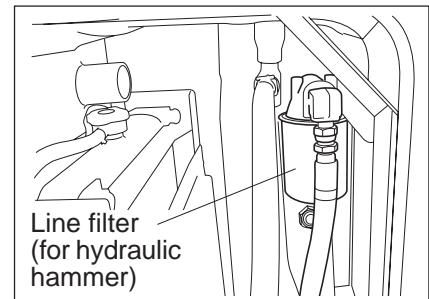
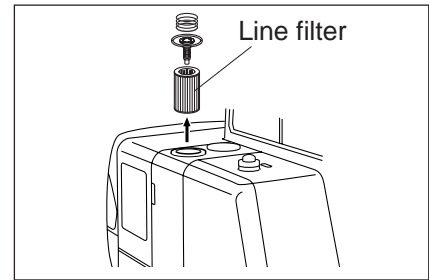

- 2) Cleaning the pilot filter  
Remove the plug from under the floor plate with a spanner (width across flats:27 mm) and pull out the element.  
Clean the element with cleaning oil and remove all dirt.

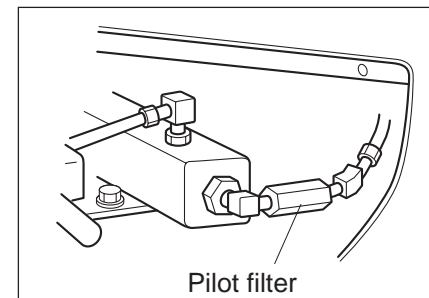

- 3) Cleaning the suction filter  
Remove the suction filter from the hydraulic oil tank. Clean the filter with diesel fuel or kerosene to remove the dirt. If the strainer is broken, replace it with new one.

## IMPORTANT

To reinstall the lid, set the O-ring securely into the flange groove in order to prevent a leak of hydraulic oil.

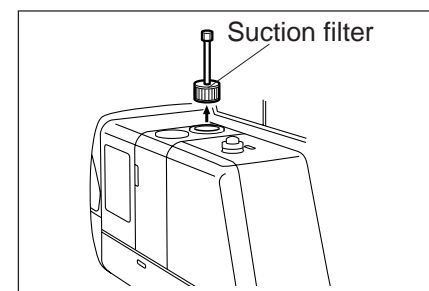

## CAUTION

Do not perform this operation while the hydraulic oil is still hot, to avoid being burned.

Diesel Engines

ABS	Agco-Sisu
Akasaka	Baudouin
BMW	Bukh
Caterpillar	CHN 25/34
Cummins	Daihatsu
Detroit	Deutz
Doosan-Daewoo	Fiat
Ford	GE
Grenaa	Guascor
Hanshin	Hatz
Hino	Honda
Hyundai	Isotta
Isuzu	Iveco
John-Deere	Kelvin
Kioti	Komatsu
Kubota	Liebherr
Lister	Lombardini
MAK	MAN B&W
Mercedes	Mercruiser
Mirrlees BS	Mitsubishi
MTU	MWM
Niigata	Paxman
Perkins	Pielstick
Rolls / Bergen	Ruggerini
Ruston	Scania
Shibaura	Sisu-Valmet
SKL	Smit-Bolnes
Sole	Stork
VM-Motori	Volvo
Volvo Penta	Westerbeke
Wichmann	Yanmar

Machinery

ABG	Airman
Akerman	Ammann
Astra	Atlas Copco
Atlas Weyha.	Atlet
Bell	Bendi
Bigjoe	Bobcat
Bomag	BT
Carelift	Case
Caterpillar	Cesab
Challenger	Champion
Claas	Clark
Combilift	Crown
Daewoo-Doosan	Demag
Deutz-Fahr	Dressta

Machinery

Drott	Dynapack
Extec	Faun
Fendt	Fiat
Fiatallis	Flexicoil
Furukawa	Gehl
Genie	Grove-gmk
Halla	Hamm
Hangcha	Hanix
Hanomag	Hartl
Haulpack	Hiab
Hidromek	Hino truck
Hitachi	Hyster
Hyundai	IHI
Ingersoll-rand	JCB
JLG	John-Deere
Jungheinrich	Kalmar
Kato	Kioti
Kleeman	Kobelco
Komatsu	Kramer
Kubota	Lamborghini
Landini	Liebherr
Linde	Link-belt
Manitou	Massey-Ferg.
Mccormick	MDI-Yutani
Mitsubishi	Moxy
Mustang	Neusson
New-Holland	Nichiyu
Nissan	OK
OM-Pimespo	others-tech
Pel-Job	PH-mining
Poclain	Powerscreen
Same	Samsung
Sandvik	Scania
Schaefer	Schramm
Sennebogen	Shangli
Shibaura	Steiger
Steinbock	Steyr
Still	Sumitomo
Super-pac	Tadano
Takeuchi	TCM
Terex	Toyota
Valpadana	Venieri
Versatile	Vogele
Volvo	Weidemann
Wirtgen	Yale
YAM	Yanmar